



Change the way you see the solar light

# VENUS

SOLAR FLOOD LIGHT  
with motion sensor



# VENUS

## SOLAR FLOOD LIGHT with motion sensor

**V**ENUS solar flood light was developed to satisfy the demand of premium customers who are caring about the quality, not limited the finishing of lights, but also the aesthetic appearance, battery stability, lighting efficiency, also convenient operation, and motion sensor detection.

VENUS solar-led floodlight adopts the latest technology of control system to balance between the solar panel, lithium battery. The brand new lithium battery is built inside to store the energy to extend the light lifetime up to 10 years. The quality solar panel is able to charge the battery well even during very challenging days no matter in cloudy days or wintertime, ensure to provide continuous lighting service without blackout.

Microwave motion sensor function could be turned ON/OFF freely via 2.4G remote control, The popular lighting programs are built in to allow users to select easily, what's more, the light also can work at day time when the battery is charging by the solar panel. One 2.4G remote control would control all the lights in the same group within 20 meters.

VENUS will be the perfect solar light to expand your business.



# Main Features

Our research in 2020 has shown all customers positively believe there is a huge demand for a high-quality solar flood light in their local market. More than 90% of customers are unsatisfied with the quality of the existing solar flood lights on the market. The VENUS solar flood light is specially developed with its clear and high-quality positioning to satisfy all the expectations of premium customers. Different from models on market, VENUS solar flood light is making a lot of improvements:

- > Equipped with brand new lifepo4 battery instead of recycled ones from E-vehicles.
- > Equipped with 2.4G remote with 360° signal transmission, more sensitivity and longer distance
- > Equipped with microwave sensor , multi-lighting functions optional.
- > Equipped with the highest lighting efficiency LED chip up to 200lm/w max.
- > Equipped with a separated adapter cable for more easier connection.
- > Equipped with stainless steel ON/OFF button.
- > Improved installation method of solar panel, more user-friendly installation.



# Key Components



## **2.4G remote control**

Long distance with 360 degrees signal transmission, one remote can control multi solar lights at same time in same area.



## **lifepo4 battery**

Brand new, ultra long lifetime, big capacity of LifePO4 battery pack is built inside guarantees system to work stably



## **adapter cable**

Individual 4.5 meters cable to connect solar panel and light fixture, It makes the installation more easier and flexible

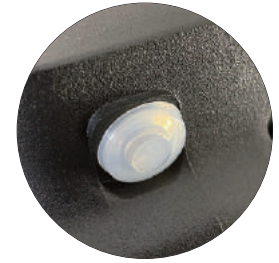

## **switch button**

Stainless steel button with rubber cap covered is adopted for easy operation.



## **motion sensor**

Built in motion sensor program. off+100% power for 1 minute, or 30%+100% power when sensor is triggered.

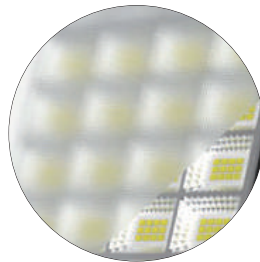

## **woven glass**

Lighting performance is becoming more uniformed with 4.0mm woven glass, and makes lights look more elegant.

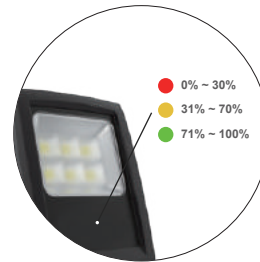

## **indicator light**

Different color of indicator lights shows the rest battery capacity , Convenient for maintenance.



## **bracket cap**

Bracket is stronger with cap ,easy to adjust the angle and more aesthetic.

# Detailed Specification



Environmental Protection



Remote Setting



2000 Cycles LifePO4 Battery



Electricity Bills free



High luminous efficiency



30%+100%

Motion Sensor Detection



ON - OFF

Dusk to Dawn Auto ON/OFF



IP 65

IP65 Waterproof

| Model                        | V2-PRO                | V4-PRO       | V6-PRO       | V8-PRO                 |
|------------------------------|-----------------------|--------------|--------------|------------------------|
| Luminous flux (max)          | 880lm max             | 1,280lm max  | 2,480lm max  | 3,280lm max            |
| Led power (max)              | 4.8W max              | 9.0W max     | 13.5W max    | 18.5W max              |
| Fixture dimension            | 240*168*56mm          | 305*235*56mm | 375*275*56mm | 375*275*56mm           |
| Solar panel                  | 12W 10V               | 25W 10V      | 35W 10V      | 50W 10V ( 2pcs of 25w) |
| Lithium battery              | 6.4V 38.4WH           | 6.4V 76.8WH  | 6.4V 115WH   | 6.4V 154WH             |
| Fixture color                | White / Grey / Black  |              |              |                        |
| Color tempature              | 3000K / 4000K / 6000K |              |              |                        |
| Housing material             | Aluminium die casting |              |              |                        |
| Remote control               | 2.4G radio remote     |              |              |                        |
| Charging time                | 4.5 hours             |              |              |                        |
| Discharging time             | >15 hours             |              |              |                        |
| Working temp.                | -15 C ~ +70 C         |              |              |                        |
| Connect cable                | 4.5 meters            |              |              |                        |
| IP rate                      | IP65                  |              |              |                        |
| Certificates                 | CE ROHS, CB           |              |              |                        |
| Packing Information          |                       |              |              |                        |
| Carton Size                  | 52*40*38cm            | 54*40*49cm   | 64*28*42cm   | 64*30*42cm             |
| Quantity / Carton            | 6 sets                | 4 sets       | 2 sets       | 2 sets                 |
| Net Weight                   | 17.80kg               | 18.80kg      | 14.50kg      | 16.30kg                |
| Gross Weight                 | 19.20kg               | 20.30kg      | 15.60kg      | 17.80kg                |
| Solar panel+light in one box | Yes                   | Yes          | Yes          | Yes                    |

## Dimension



V2-PRO

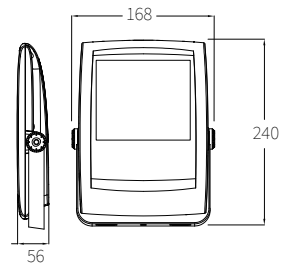

V4-PRO

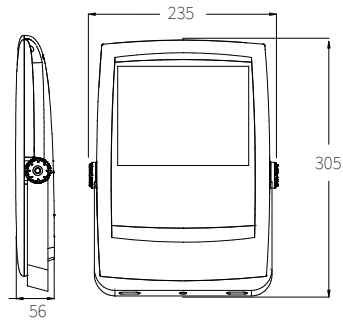

V6-PRO

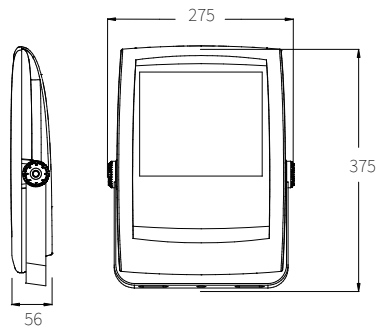

## Application

\* Temporary Tent Lighting

\* Pathway Lighting

\* Warehouse Lighting

\* Refugee Tent Lighting

\* Construction Site Lighting

\* Bus Station Lighting

\* Emergency Lighting

\* Garden Lighting

\* Hotel Lighting

\* Horse Stable Lighting



## Lighting Area

| Model  | Luminous flux | Lighting area          |
|--------|---------------|------------------------|
| V2-PRO | 880lm         | 12 ~ 20 m <sup>2</sup> |
| V4-PRO | 1680lm        | 20 ~ 35 m <sup>2</sup> |
| V6-PRO | 2480lm        | 35 ~ 45 m <sup>2</sup> |
| V8-PRO | 3280lm        | 45 ~ 60 m <sup>2</sup> |





---

Technical Collaboration with Truelite USA & MR.AURORAS China



Visit our website

**AURORAS INNOTECH (GUANGDONG) CO., LTD**

[www.truelite.us](http://www.truelite.us)    [www.auroraslighting.com](http://www.auroraslighting.com)

Telephone : +86 0760 86687850    86687851

Email : [Sales09@auroraslighting.com](mailto:Sales09@auroraslighting.com)

Address : 2/F, B# Bldg, 1# Dongcheng Rd, SanXiang,  
GuangDong Post Code 528463 CHINA